

AC Servo motor

User Manual V1.2

Model: WR509&WR50U



1. Notes on safety

Please read carefully User's Guide and the manual of sewing machinery accompanied before use. Installation and operation by trained professionals and correct use are required. Read carefully the following instructions for proper use. EasyDriver servomotor series can only be used for designated sewing machinery, with no exception.

1.1 Operating Environment Security

- (1) Power Supply: Please follow the 200V—240V indicated on the nameplates of motor and control box.
- (2) Electromagnetic wave interference: Keep away from high frequency electromagnetic wave machines or electric wave emitter so as to avoid interference.
- (3) Humidity and temperature: a. Working environment: 5°C~ 45°C, room temperature
b. Keep away from sun light, indoor use only.
c. Keep away from (electric) heating appliances
d. Relative humidity: 30%~95%, keep away from dew.
- (4) Air: a. Keep away from dusty or corrosive environment. b. Keep away from volatile substance.

1.2 Installation Security

- (1) Motor, control box: follow the steps indicated in the manual
- (2) Accessories: power off and unplug power cord before installing any optional accessories.
- (3) Power cord: a. Avoid pressure or over distortion. b. Keep the power cord at least 3 cm away from upper roller.
c. Make sure that supply voltage is between 200V—240V.
- (4) Earthing: a. Handle earthing (including sewing machine, motor, control box, locator) correctly to avoid interference or creepage.
b. The earthing cord of power cord must be connected to user's system earthing cord with proper conducting wire and joint and fixed permanently.

1.3 Operation Security

- (1) Operate at low speed to check if rotation direction is correct when the sewing machine is powered on for the first time.
- (2) Do not touch the upper roller or needles when the sewing machine is running.
- (3) All movable components must be isolated by protection apparatus provided to avoid unnecessary contact and nothing shall be put inside the machine.
- (4) No operation is allowed in the absence of belt guard and other security apparatus

1.4 Maintenance

- Turn off power before conducting the following operations:
- (1) Removing motor or control box, or plugging of unplugging any plugs from the control box.
- (2) There is hazardous high voltage inside the control box. Do not open the control box until the power has been off for at least 1 minute.

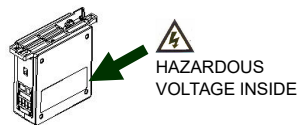

- (3) Moving machine head, replacing needles or shuttle or threading.
- (4) Repairing or any mechanical adjustment.
- (5) The machine is not running.

1.5 Regulations on Maintenance

- (1) Repair and maintenance can only be performed by trained technicians.
- (2) No irrelevant articles should be put near the motor's air vent, the back vent head, in particular, shall be kept free of dust, waster paper, broken fabric, etc to avoid overheating of the motor.
- (3) Do not hammer this machine or motor (motor) spindle.

1.6 Warning Signs & Notices

- ⚠ Used where potential dangers exist. ⚡ Used where high voltage and electric danger exist.

1.7 Regulations on Warranty period

Free repair service up to 12 months since leaving factory on condition that this machine is operated correctly and no human error occurs to it.

5. Instructions for the Operation Panel of the Chassis

Layout of the operation box of chassis, 6 digital tubes (abcdef) and 5 keys (12345)

5.1 Setting of Sewing Functions

Press key 1234 and digital tube abcd to set needle position, thread-cutting.

- (1) Needle position a: 0 upper needle position; 1 lower needle position

- (2) thread-cuttings b: 0 unavailable; 1 available

The four settings are not necessarily valid for different working mode and sewing mode.

- 1) free-style sewing, preset sewing are all valid.
- 2) none of the settings are all valid for plain sewing.
- 3) Automatic test mode: all settings are valid.

The system will enter automatic test mode if key P and power button are pressed at the same time, Press key P and 4 to start, stop running.

Display functions of digital tube ef:

- (1) Digital tube e: indicate the status of scissors safety switch.

No display for invalid scissors safety switch, animated pictures for valid scissors switch, "| → " | - " → " - " → " - | " → " | " which means that scissors has been lifted and system running is forbidden.

- (2) Digital tube f: distinguish different sewing modes

"E" for plain sewing, "A" for automatic test, no display for other modes

5.2 Setting of Parameters

Under setting mode for sewing functions, i.e. default mode of the operation box of chassis, keep pressing key P to enter setting mode for parameters. Digital tube abcd display parameter values which can be modified by pressing key 34; digital tube ef display parameter numbers which can be modified by pressing key 12, and previous parameters will be saved at the same time. Press key P to exit setting mode for parameters, and the current parameter values will be saved.

Press key 1234 short for change each time, long to keep increasing or decreasing rapidly.

Note: the setting mode for parameters can not be entered into when the system is running; exit to enter setting mode for parameters. See the parameter list of system for details.

5.3 System monitoring status

Under the default mode of the HMI of chassis, press key p and key 1 at the same time to enter system monitoring status. Digital tubes abcd display monitoring values; digital tubes ef display monitoring parameter number, press key 12 for modification.

ef	abcd	unit
1	speed	spm
2	current	A
3	voltage	V
4	Piecework number	piece

5.4 Status of System Error

System will stop when an error is detected and error code will be displayed by the operation panel of chassis. Digital tube abcd display error number. See error code list for details.

6. Parameter list of system

No	Items	Contents	Settings range	Default
1	highest speed of free-style sewing	set the highest speed for machine head	300~4000spm	3500
2	Soft Start	soft start setting for starting sewing 0: no Soft Start 1~9: needle number of soft start	0~9	3
3	soft start speed 1	soft start speed for starting sewing 1	100~1000(spm)	400
4	soft start speed 2	soft start speed for starting sewing 2	100~1500(spm)	800
5	soft start speed 3	soft start speed for starting sewing 3	100~4000(spm)	1200
6	soft start speed 4	soft start speed for starting sewing 4	100~4000(spm)	1200
7	soft start speed 5	soft start speed for starting sewing 5~9	100~4000(spm)	1200
8	Highest speed for preset sewing	Highest speed for preset sewing	300~1500(spm)	3000
9	Sewing mode	Sewing mode setting(valid in the absence of operation box of the machine head) 0:free-style sewing 1:preset sewing 2:plain sewing	0~2	0

2. Installation and Adjustment

2.1 Installation of Drive Board

(a) Dimensions of control box

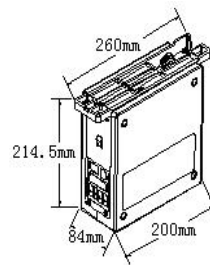

(b) At least 100mm shall be reserved for the right side of the sewing machine table.

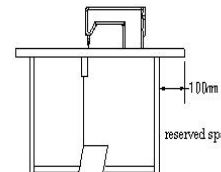

(c) After installation

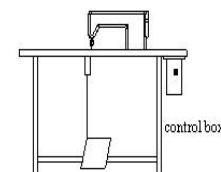

2.4 Adjustment of pedal

The parts of pedal are as shown in the left figure.

- A. Operation spring
- B. Bolt for heeling force adjustment
- C. Pedal lever
- D. Ball joint link

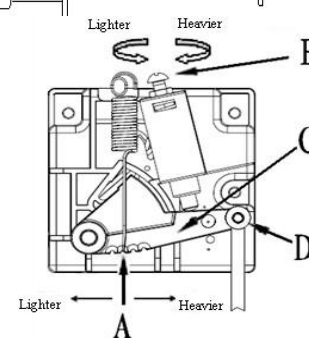

No.	Adjustment	Result
1	Adjustment of toeing force	Move spring A to the right to increase the toeing force. Move spring A to the left to reduce the toeing force.
2	Adjustment of heeling force	CCW ↺ turn the bolt to reduce the heeling force. CW ↻ turn the bolt to increase the heeling force.
3	Adjustment of pedal stroke	Secure the ball joint link D to the right hole to increase the pedal stroke. Secure the ball joint link D to the left hole to reduce the pedal stroke.

3. Connection & Earthing

Qualified electric engineering professionals must be invited for system earthing.

4. Names of Chassis Components

4.1 Front Side

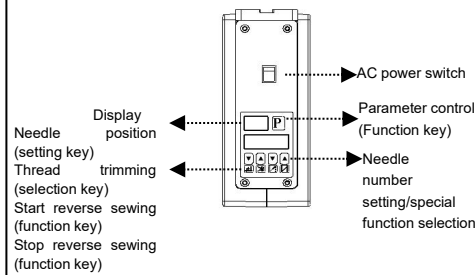

4.2 Back Side: connector

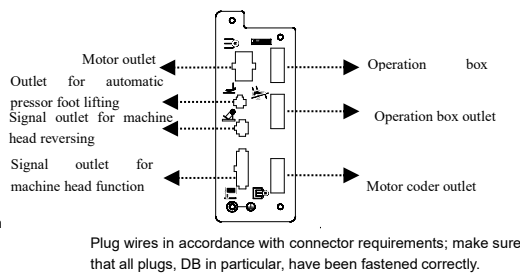

Plug wires in accordance with connector requirements; make sure that all plugs, DB in particular, have been fastened correctly.

No	Items	Contents	Settings range	Default
10	Number of preset sewing sections	Setting the number of preset sewing sections and the needle number of each section	1~2(sections)	1
11	needles of the 1 st section of preset sewing		1~99(needles)	15
12	needles of the 2 nd section of preset sewing		1~99(needles)	15
13	trigger mode of preset sewing	setting of preset sewing trigger (valid in the absence of operation box of the machine head) 0: trigger function unavailable 1: trigger function available	0/1	0
15	control mode for pressor foot lifting	settings of pressor foot lifting mode 0: pressor foot lifting unavailable 1: treadle pressor foot lifting 2: automatic pressor foot lifting after thread-cutting 3: automatic pressor foot lifting after treadle pressor foot lifting and thread-cutting 4: automatic pressor foot lifting after machine stopping and thread-cutting 5: automatic pressor foot lifting after treadle pressor foot lifting, machine stopping and thread-cutting	0~5	1
16	treadle command mode after thread-cutting	treadle command mode setting after thread-cutting 0: thread-cutting command unavailable for pressor foot lifting 1: thread-cutting command available for pressor foot lifting	0/1	1
20	Power on and positioning	Setting of machine head moving to upper needle position when powered on 0: unavailable 1: available	0/1	1
21	Signal mode for scissors safety switch	Setting of signal mode of scissors safety switch of machine head 0: always open 1: always close	0/1	1
23	piecework	Piecework setting 0: unavailable 1: available	0/1	1
24	piecework display	Piecework number	0~9999	0
27	low speed	lowest speed of treadle	100~1000(spm)	200
28	adjustment of treadle functions	Adjustment of the speed adjustment functions of treadle	10~100	60
30	thread-cutting delay time	thread-cutting delay time	0~200(ms)	0
31	thread-cutting action time	thread-cutting action time	0~1000(ms)	120
32	For the delay time line	For the delay time line	0~300(ms)	40
33	Time line for action	Time line for action	0~1000(ms)	30
34	pressor foot lifting delays sewing	pressor foot lifting delays sewing	0~1000(ms)	30
35	output time of total pressure of pressor foot lifting	output time of total pressure of pressor foot lifting	0~800(ms)	250
36	output duty cycle of pressor foot lifting	output duty cycle of pressor foot lifting	0~100	22
37	hold time of pressor foot lifting	forced shut-down after hold time of pressor foot lifting	1~60(s)	12
38	Output time of total pressure of reverse-sewing	Delay with pressor foot lowered	0~800(ms)	200
40	lower needle position	Adjustment of lower needle position	120~240	180
49	parameter of special functions	Parameter of special functions(valid after holding 2s) 5: return to factory-set parameter	0~15	0

7. Instructions for System Configuration

7.1 Adjustment of Sewing Speed (parameter No.1, 4, 27-28, 50)

1) Highest speed of free-style sewing (parameter No.1)

Setting of the highest speed of treadle under free-style sewing mode, the max value is subject to parameter No.50.

(Note) lifetime of the sewing machine may be reduced by unnecessary high speed

2) Setting of preset sewing speed (parameter No.4)

Parameters of various preset sewing speeds

3) Low speed setting (parameter No.27)

Treadle's starting and running speed. It will be easy to conduct needle compensation with treadle

4) Adjustment of the speed adjustment performance of treadle(parameter No.28)

User can customize speed adjustment performance of treadle, bigger parameter leads to higher acceleration of treadle, otherwise lower. Too big value may make working uncomfortable; too small may fail the highest speed set.

Increase the parameter if treadle is unable to reach the highest speed.

7.2 Soft Start (parameter No.2-3)

Top stitches and bottom stitches of starting sewing may be unable to link if needle distance is too short or needle is too thick, which can be improved by limiting the highest starting sewing speed.

No.2 setting of needle number of soft start

0 Soft Start invalid

1~9 needle number of soft start, i.e. limit speed with certain needle number under starting sewing mode

No.3 setting of soft start speed

7.3 Setting of Needle positioning (parameter No.40)

1) Selection of upper and lower needle position

By default, the 1st key on the lower left controls stopping needle position, corresponding upper figure display the value set

0 upper needle position

1 lower needle position

2) Adjustment of lower needle position(parameter No.40)

Setting of lower needle position, deviation angle relative to upper needle position

7.4 Sewing Mode setting (parameter No. 5-13)

Special pattern may be realized by setting parameters.

1) selection of sewing mode(parameter No.5)

Free-style sewing: Able to keep running after treadle has been pressed, no needle number will be counted.

a) Preset sewing: the machine automatically stop when reach certain needle number, stopping times (parameter No.6) and needle number (parameter No.7-12) of stopping can be set.

b) Plain sewing: stopping needle position is free, no needle number will be counted, reinforcing-sewing mode invalid, manual reverse-sewing and automatic pressor foot lifting is available. This mode will be useful if the synchronizer of machine head is damaged.

2) setting of number of preset sewing sections and needle of each section(parameter No.6-12)

Section number for preset sewing (parameter No.6): 1~7; needle number for each section (parameter No.7-12): 1~99.

3) trigger function of preset sewing (parameter No.13)

Decide whether sewing will be completed without stop at each section under preset sewing mode. Machine can be stopped at each section during running if this function is invalid.

4) setting of thread-cutting

By default, the 2nd key on the lower left control thread-cutting function, corresponding upper figure display the value set.

0 thread-cutting unavailable

1 thread-cutting available

7.5 Pressor Foot Lifting Mode setting (parameter No.15)

Set the operation mode of the magnet of pressor foot lifting.

0 magnet operation unavailable

1 Only treadle command can conduct pressor foot lifting

2 automatic pressor foot lifting after thread-cutting

3 treadle operation, automatic operation after thread-cutting

4 automatic operation after machine stopping and thread-cutting

5 treadle operation, automatic operation after machine stopping and thread-cutting

(Note) set parameter No.25 to 0 if the magnet of pressor foot lifting is unavailable

-5-

7.6 Treadle Setting after Thread-cutting (parameter No.16)

Move treadle to thread-cutting status after thread-cutting is completed to send pressor foot lifting command setting.

If parameter No.15 is set to 1, 3, 5, then pressor foot lifting will be executed.

This function is used to facilitate pressor foot lifting after thread-cutting.

7.7 Automatic Top Positioning When Powered-On (parameter No.20)

When powered on, the machine head will automatically move to upper needle position, which can facilitate sewing.

No action if needle position is around upper needle position.

7.8 Roll-over Protection (parameter No.21)

Lock machine's functions to prevent unexpected accident when scissors did not return. Parameter No.21 controls types of roller-over signals.

When machine Lock protection, the digital tube on the upper left 1 of the operation panel of chassis will display roller-over picture.

7.9 Sewing Piecework (parameter No.23-24)

Counts will increase when thread-cutting is over to calculate finished sewing working procedures.

If No.23 is set to 1, piecework is available; if set to 0, piecework is unavailable.

No.24 display piecework number, press parameter value to clear piecework number for recounting.

7.10 adjustment stands tread cutting for pressor foot lifting.(No. 30-34)

No.30 thread-cutting delay time ttd: After the shutdown began moves to the next scissors time

No.31 thread-cutting action time tto: Action under the scissors of time

No.32 f For the delay time line twd: Under the scissors for action to end the time-start movement

No.33 For the delay time line e two: Time line for action

No.34 pressor foot lifting delay time tfd: Action Line for the end of foot movements to raise the pressure of time

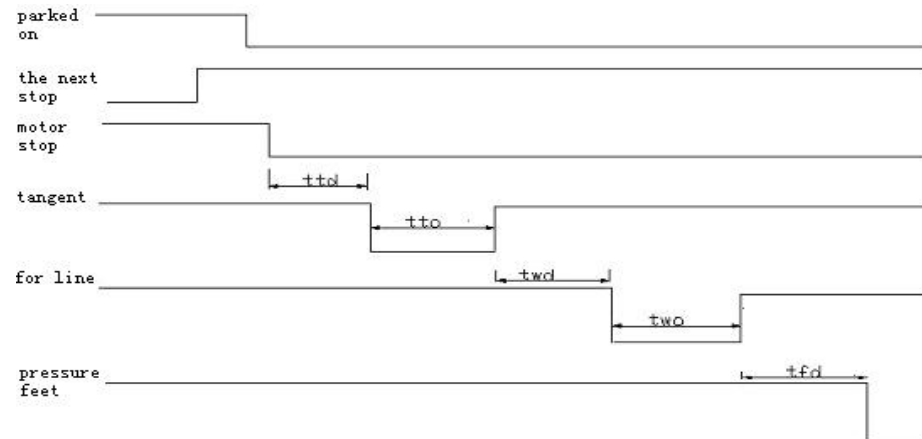

7.11 Pressor Foot Lifting Hold Time setting (parameter No.37)

Adjust the hold time of pressor foot, long time operating can reduce the lifetime of magnet.

After pressor foot is lifted, magnet will be automatically stopped to lower pressor foot after the time set by No.37.

7.12 Sewing with Delayed Pressor Foot (parameter No.38)

When the magnet of pressor foot lifting operates, press treadle. Since it takes time for magnet to release, sewing machine may have begun running before pressor foot press materials firmly, affecting sewing effects. Parameter can be used to compensate the time for pressor foot lifting to release.

-6-

8. Error Code Table

Error codes	Contents	Possible reasons for the failure	Checking and treatment
E011 E012 E013 E014	electric engine signal error	Motor position sensor signal failure	If electric engine plug is well contacted if electric engine signal detecting device has been broken if sewing machine handwheel correctly installed
E021 E022 E023	electric engine overload	motor stall electric engine overload	If electric engine plug is well contacted if machine head or thread-cutting mechanism has been blocked completely if materials are too thick Electrical signal detection signal whether the normal
E101	Hardware drivers fault	Current detection of non-normal Driving through the device	Current detection loop system is working properly Whether the damage to the device driver
E111 E112 E113	Voltage too high	High-voltage reality Brake failure loop Motor testing is wrong	If the voltage on the inlet wire is too high Braking resistance is the normal work Whether the system voltage detection circuit the normal work
E121 E122	Voltage too low	Actual low voltage Voltage detection is wrong	If the voltage on the inlet wire is too low Whether the system voltage detection circuit the normal work
E131	Circuit fault detection circuit	Current detection of non-normal	Current detection loop system is working properly
E141	Failure to read and write data system	Non-normal data systems to read and write	Current detection loop system is working properly Whether the data chip damage
E151 E152	magnet error	Electromagnet return flowElectromagnet non-normal conduction	If machine head magnet suffers short circuit Electromagnet circuit is working properly
E201	Motor current excessive	Current detection of non-normal The normal functioning of non-motor	Current detection loop system is working properly Electrical signal is normal
E211 E212	Abnormal electric engine operation	Abnormal electric engine operation	If electric engine plug is well contacted If electric engine signal is matched
P.oFF	Power-fail	Power-down	Wait for power supply to resume
LED1 Animation	Refill oil	Shear-effective safety switch	Scissors in the back

Note: consult technical support if errors still exist.

-7-

9.PACKING LIST

WR509/WR50U PACKING LIST V1.2

Number	Products name	Amount	product specification	Confirm	Remarks
1	Ball joint link	1			
2	Electric control cabinet	1	WR509/WR50U		
3	Operating box	1	EP-001		containing its support
4	Screw for electric control cabinet fixing	3	M5×30		Outside hexagon flange head self-drilling tapping screws
5	Screw for pedal fixing	3	M5×23		Outside hexagon flange head self-drilling tapping screws
6	Instruction book	1			
7	Conformity certification	1			
8	Banding rope		CV-160L		

-8-